

Truck-mounted concrete pump

BSF 54-5.16 H

.16 H LS

Output up to 160 m³/h
 Delivery pressure up to 130 bar*

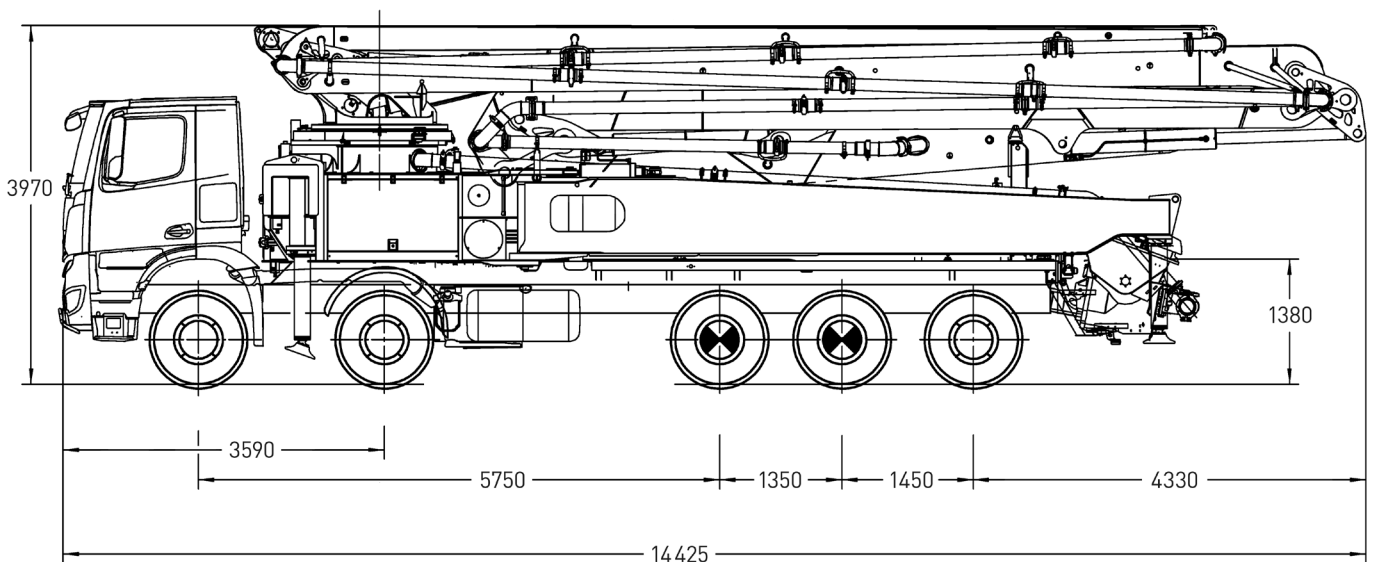
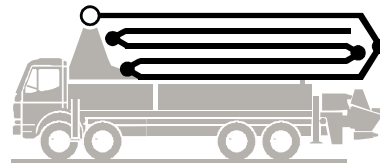

Note: Standard version. Dimensions and weights depend on truck, pump model and equipment.
 Dimensions in mm, MB-Arocs 4851, Euro 6.
 For illustration only.

Technical data

Boom M 54-5		
Sections		5
Reach height	m	53.6
Horizontal reach	gross	m 48.4
	net	m 44.0
Reach depth max.	m	39.8
Unfolding height	m	15.4
End hose length	m	4
Folding system		RZ
Delivery line		DN 125

Pump		BSF	.16 H	.16 H LS
Rod side	Output	m ³ /h	160	-
	Delivery pressure	bar	85	-
	Strokes	1/min.	31	-
Piston side	Output	m ³ /h	108	160
	Delivery pressure	bar	130*	85
	Strokes	1/min.	21	26
	Delivery cylinder	Ø mm	230	250
	Stroke	mm	2100	2100

*) Delivery line boom max. 85 bar.
 All data maximum theoretical.

Reach information diagram, Support

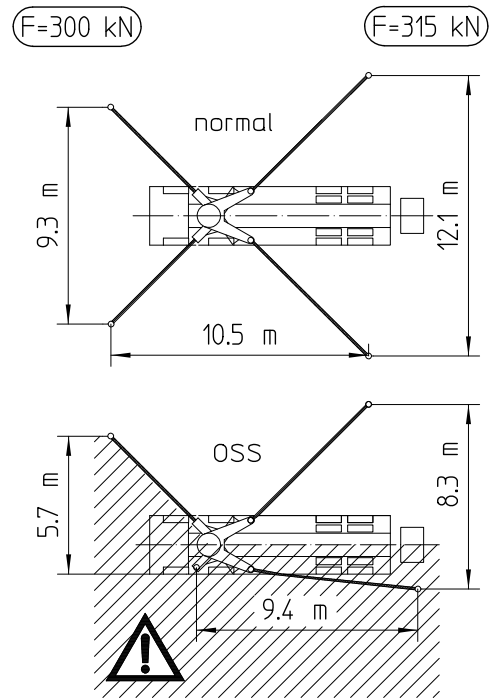
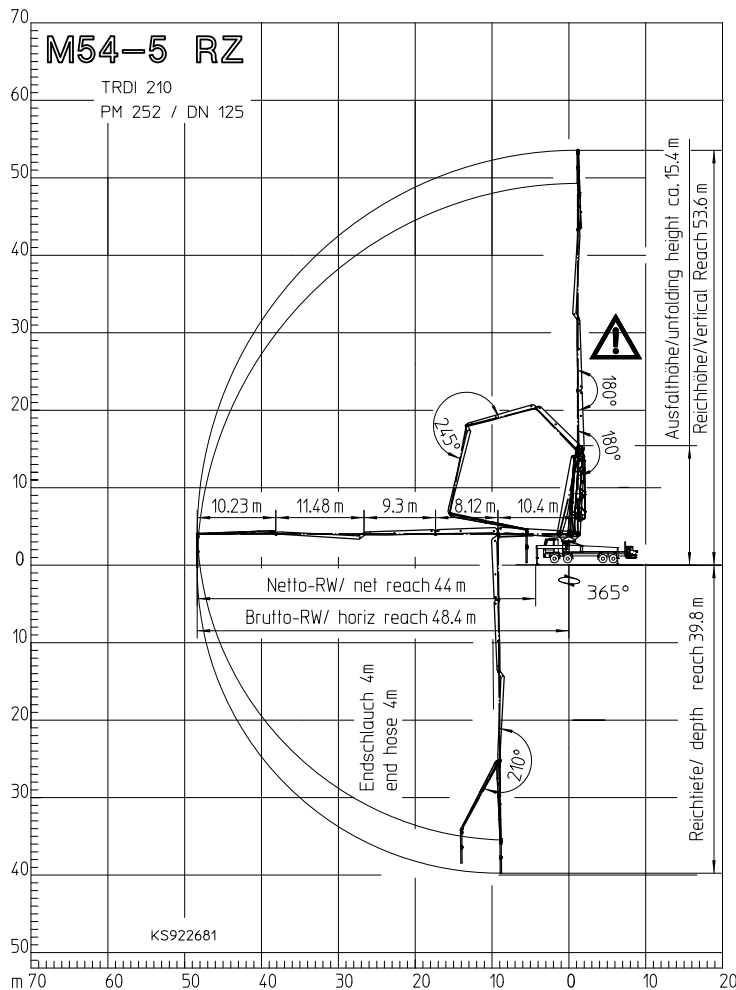

Dimensions can differ depending on configuration.

Range in which you must not work with the end hose.

Serial delivery scope

C-pipe connection for filling water tank	Chassis horn via remote control on hopper	Platform non-skid
Cardan shaft maintenance free	Connection Diesel tanks (only MB/MAN-Chassis)	Pump on/off dependent on speed
Diesel tank in support leg	Connections for hydraulic emergency supply	Radio remote control proportional with display
Ergonic Graphic Display (EGD) with machine fault management	Delivery cylinder chrome-plated	Remote control with 40m cable, without display
Ergonic Pump System (EPS) incl. Ergonic Output Control (EOC)	Delivery line (2-layer) PM2520	Rubber collar on concrete hopper
Ergonic Teleservice (ETS) without SIM Card	Delivery piston „compact“	Single piston
OSS one side support(assistance device), NOT for EWR-Area	Diagnose interface	Spectacle wear plate DURO 22
S-transfer tube switchover fast/slow	End hose 4.0 m DN 125 5.5"	Spray hose 10 m incl. bracket
Tool set incl. standard equipment	Flushing water pump 160 l/min 25 bar	Steps, first step foldable
Agitator and water pump radio remote/ on site controlled	Hand working search light lighting hopper LED	Support plates (4x) in magazine (2x) open
Agitator safety switch off, RFID with startup protection	Hinged elbow with cleaning port	Swivel support plates
Boom pedestal TRDI	Hydraulic hose for replacement in hose pack	Towing eye
Box for sponge balls	Lattice box rear side	Wash-out port lid with slide pin
Central lubrication hopper, electrically	Lighting modul control box, LED	Water supply at hopper (1/2")
	Operating manuals 2x (1x paper, 1x CD-ROM) spare part list	Water tank 800 l
	Painting Standard	

See quotation for exact serial delivery scope. Comprehensive range of options available on request.