

# PUMI®

# 28-4.79 S

Truck-mounted concrete pump with mixer

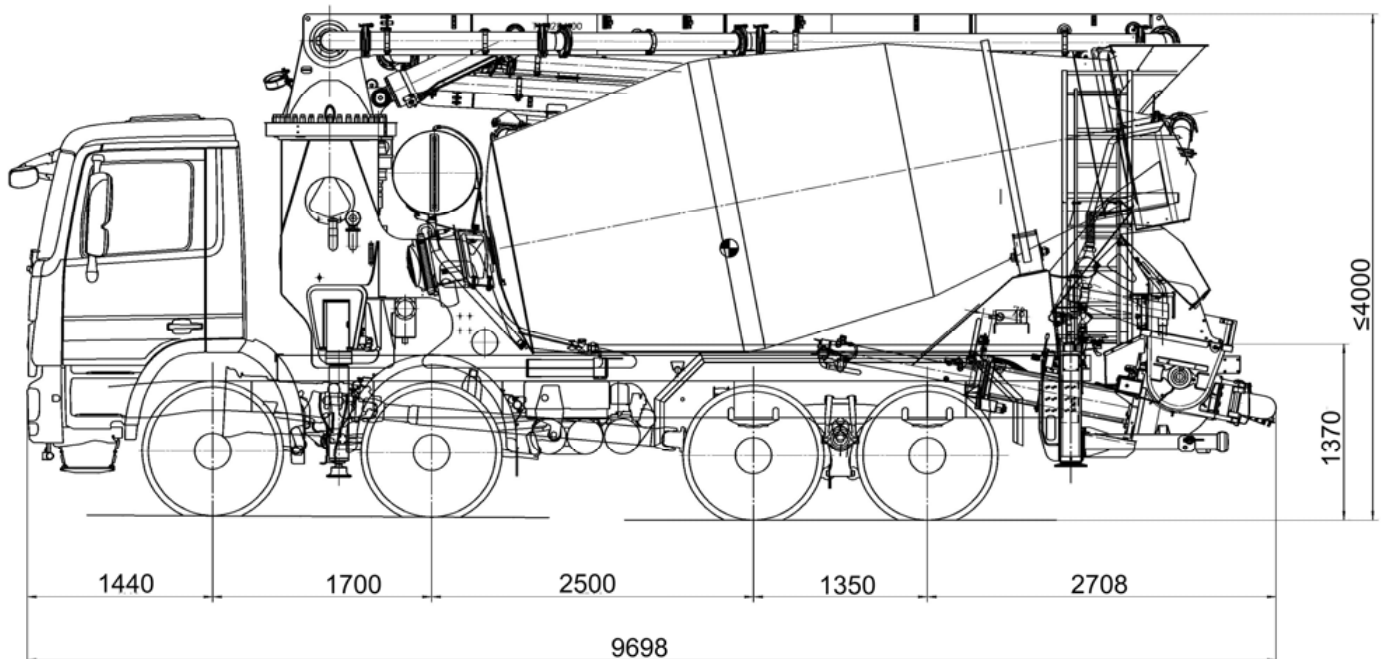

Note: Standard version. Subject to technical modifications and errors.  
 Dimensions in mm, for example MB-Arocs and PUMI S., illustration may differ.  
 Dimensions depending on the vehicle and pump type (see adjacent table).  
 Pictures contain optional equipments.

## Technical data

Boom TMM 28-4		
Number of arms		4
Reach height	m	27.8
Horizontal reach	gross	m 24.0
	net	m 21.8
Reach depth max.	m	18.9
Unfolding height	m	6.5
End hose length	m	3
Folding system		Z fold (Z)
Delivery line		DN 125 – 5,5

System S		TMP 1007 S	
Delivery cylinder	Ø mm	230	
Stroke	mm	1000	
Standard: Drive piston side			
Output	m <sup>3</sup> /h	70	
Delivery pressure	bar	75	
Strokes	1/min.	28	
Optional: Drive rod side			
Output	m <sup>3</sup> /h	92	
Delivery pressure	bar	51	
Strokes	1/min.	37	

Truck mixer 9 cbm		
Nominal capacity	m <sup>3</sup>	9
Total volume	m <sup>3</sup>	13.9
Filling ratio	%	65
Drum speed	rpm	1 – 14
Water tank	l	650

Maximum outputs of 92 m<sup>3</sup>/h and maximum concrete pressures of 75 bar may be achieved, depending on the equipment of the machine.

It is not possible to achieve maximum outputs and maximum concrete pressures simultaneously.

All data maximum theoretical.

## Reach information diagram

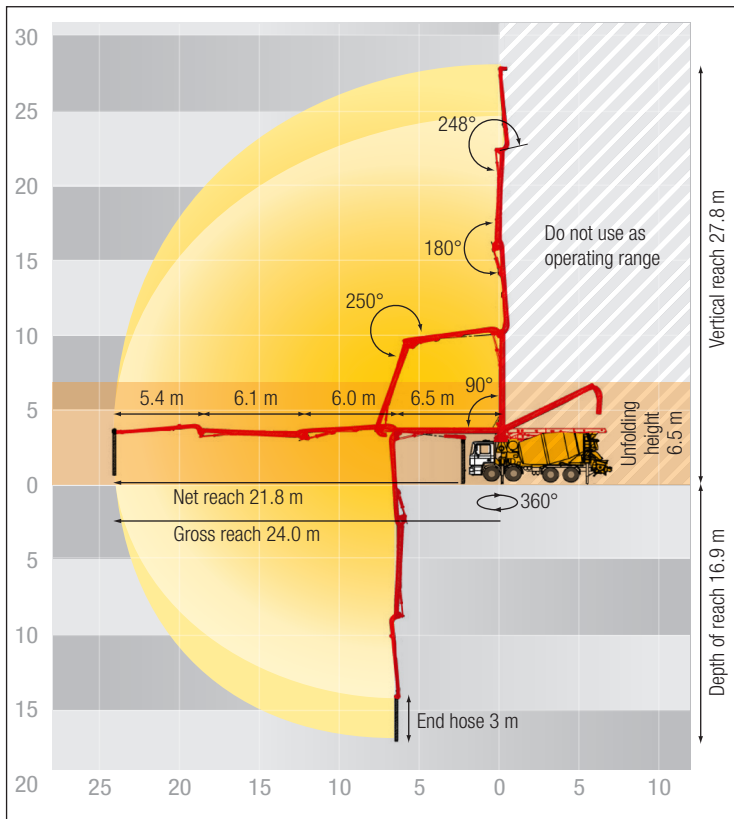

## Support

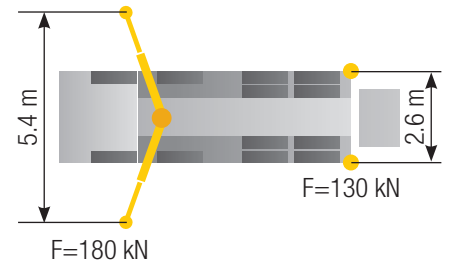

## Delivery scope standard equipment

### Support

- ESC (Ergonic Setup System) with full support
- Support plates (4x), in 2 magazines
- Support legs front T 5,4
- Support legs rear T 0

### Lighting

- Working light to illuminate hopper, mounted
- Hand working light, portable
- Marker lamps lateral and rear side, LED
- License plate lighting, LED
- Rear lights and license plate lighting, integrated in underrun protection

### Extras

- Paintwork Putzmeister Standard
- Operating instruction and spare parts manual (1x paper, 1x CD-ROM)
- Tool kit incl. standard equipment
- Hose bracket for DN65 6 x 5 m

### Delivery Line

- Delivery line (1-layer) DN125
- End hose 3 m DN125

### Mixer

- Truck mixer 9 m<sup>3</sup>
- Wear plates for filling and discharge hopper and slewable chute
- Chute, slewable
- Chute adjustment hydraulic-electrical
- Mixer discharge automatically, level indicator controlled
- Mixer drum with 4 end spiral metal sheets
- Second drip ring on mixer drum
- Second manhole opening with additional mixer drum adjustment

### Core Pump / Hopper

- Delivery piston "Longlife"
- Delivery cylinder, chrome-plated
- Hopper grid
- Central lubrication hopper, electrically
- Rubber collar on concrete hopper
- Hinged elbow with cleaning port
- Wash-out port lid with locked slide pin
- Agitator rotation automatic, dep. on pump direction
- Agitator, controllable via remote control or local
- Agitator active while driving on jobsite

### Cleaning

- Water tank 650 l, pressure tank
- Cleaning hose 8 m + 2 m incl. bracket and nozzle
- Connection for water tank filling, both-sided
- Faucet below the water tank

### Safety

- Platform for cleaning with drop guard
- Agitator safety switch off (RFID)
- Hopper cover, rubber
- Underrun protection, rear side
- Warning signal, boom not in cradle
- Towing eye

### Control System

- Ergonic 1 control system
- Radio remote control, with display
- Cable remote control, with 25m cable
- Electric control box incl. Ergonic diag. Interface, with display
- EMC (Ergonic Mixer Control)
- EMC mixer comfort function via radio remote
- EMC mixer control via radio remote control
- EOC (Ergonic Output Control)
- EPS (Ergonic Pump System)

Please refer to our offer for the complete standard scope of delivery as well as the optional equipment options.